



PQ-Hybrid

All-in-One Power Quality Solution
for Dynamic Compensation
and Harmonic Mitigation



Smart.
Fast.
Cost Effective.

Elspec PQ-Hybrid

Two Technologies. One Cost-Effective Solution

Elspec PQ-Hybrid is a hybrid power quality compensator that merges two proven technologies into one powerful solution: a thyristor-based system for ultra-fast, transient-free reactive power compensation, and an integrated IGBT-based Active Harmonic Filter (AHF) that injects counter-currents in real time to eliminate distortion from non-linear loads.

Both the AHF and reactive power compensation modules respond in less than one network cycle. This ultra-fast dual-action ensures that power disturbances are treated within the same cycle in which they occur, allowing precise synchronization, optimal correction, and improved system stability. It's the ideal architecture for dynamic, rapid-changing electrical environments.

Whether the challenge is unbalanced loads, rapid fluctuations, or distorted waveforms, the PQ-Hybrid manages them all-simultaneously and continuously. It delivers stepless reactive power compensation in SVG mode, stabilizes voltage, optimizes power factor, and filters harmonics - all within a single system.

By integrating these two technologies into one compact solution, the PQ-Hybrid significantly reduces operational costs - making it the ultimate cost-effective investment in long-term power quality.

Customer Benefits



Prevent Unplanned Downtime

Rapid load changes can cause voltage dips and equipment resets. Elspec's dual compensation within a single cycle ensures real-time stability and keeps operations running smoothly.



Protecting Equipment

Integrated harmonic filtering and transient-free switching safeguard sensitive equipment from electrical stress - reducing failures and extending operational life.



Easy Deployment & Integration

Pre-engineered for fast installation, the PQ-Hybrid fits into existing infrastructure and replaces the need for separate PFC and harmonic filtering systems - reducing wiring, setup time, and complexity - In one cabinet.



Cost-Effective Solution

The PQ-Hybrid requires minimal space, consumes little energy, and demands low maintenance. Its competitive pricing makes it cost-effective for long-term management. Typical energy losses are less than 2%, ensuring high efficiency and reduced operational expenses.

Applications Across Industries



Industrial

Pumps | Motors | VFDs | UPS



EV Infrastructure

Charging Stations with Variable Load Behavior



Renewables

PV Inverters | Battery Storage Systems (BESS)



Commercial

Office Towers | Malls | Production Hubs



Distributed PV Systems

Solar rooftops



Critical Power

Hospitals | Healthcare Facilities
Data Centers | Laboratories

How Does it Work?

Elspec PQ-Hybrid solution is installed in parallel with the electrical network, where it continuously monitors and corrects power quality issues in real time.

The diagram below illustrates how the system integrates into the power flow. As power flows from the source to various loads, including motors, VFDs, and other nonlinear equipment - the system injects corrective currents to balance reactive demand and eliminate harmonic distortion. The result is a cleaner, more stable current delivered to downstream loads.

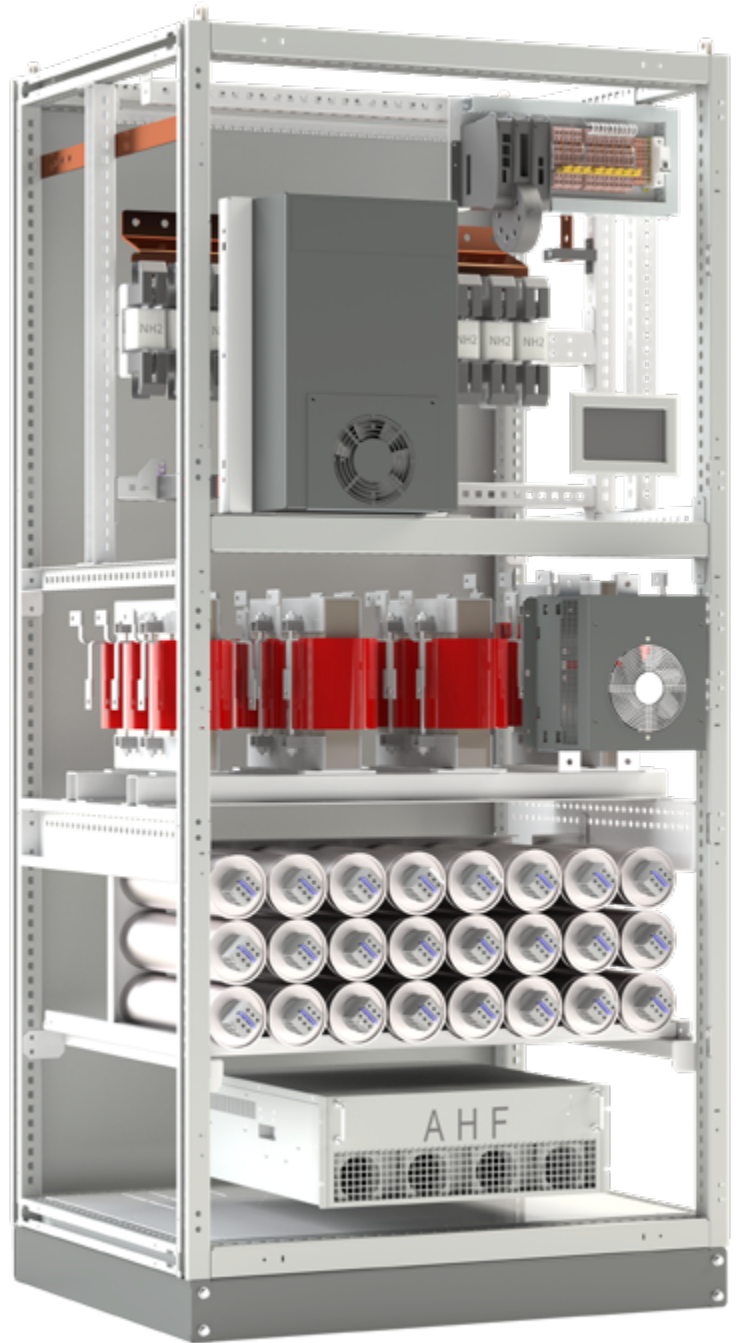

Elspec's Hybrid Solution Stands Above the Rest

Delivering Real-Time Reactive Power Compensation, Voltage Stabilization and Extra Harmonic Filtration.

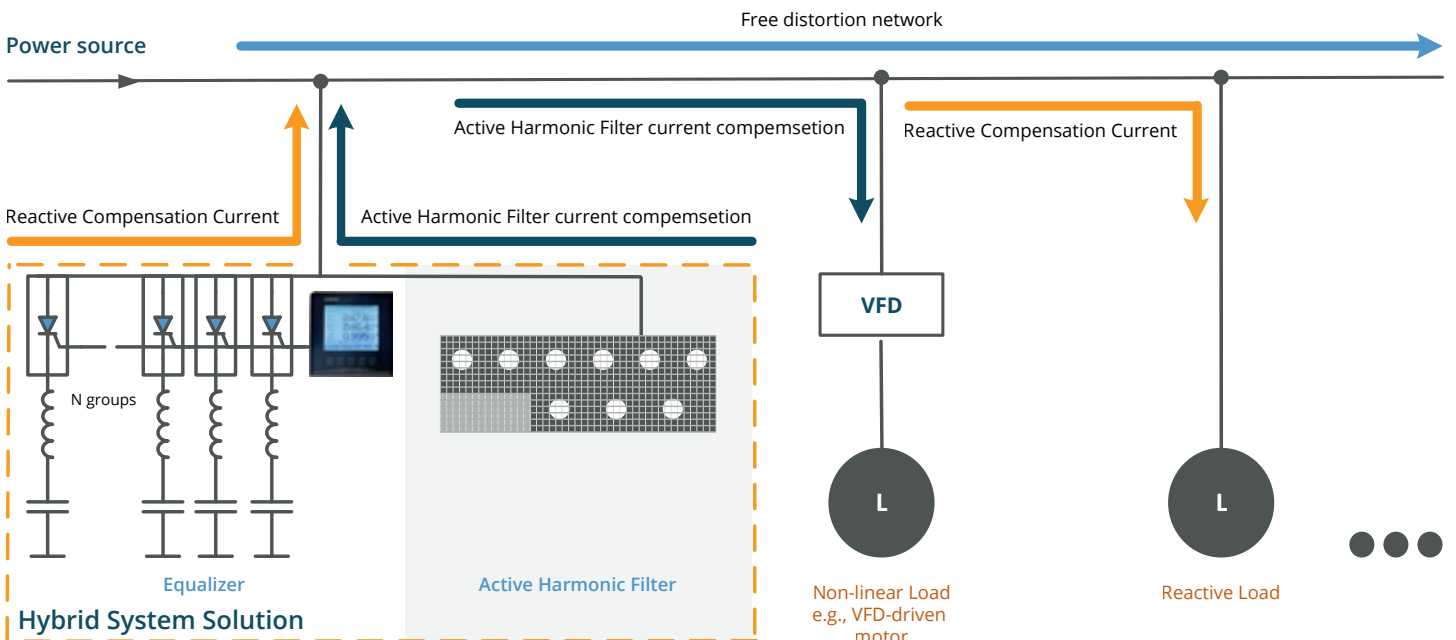

Key Features

that Set Elspec's Hybrid Solution Apart

Compensation in less than 1 cycle

In power quality speed and precision matter. Elspec's PQ-Hybrid solution acts in real-time. The system responds in less than one cycle, thanks to high-speed thyristor-based control. It continuously adapts to load variations, ensuring power factor and voltage remain stable under dynamic or unbalanced conditions.

The following graph demonstrates how the system dynamically tracks the reactive demand from the LOAD and provides real-time response and precise compensation, keeping the net reactive power at the MAIN stable, even during rapid fluctuations.

In a Hybrid solution, sub-cycle reactive compensation is vital because it stabilizes voltage and power factor instantly, preventing the AHF from being overloaded by rapid load swings. This keeps the AHF focused on filtering harmonics, ensuring both functions work in synergy for efficient, reliable power quality.

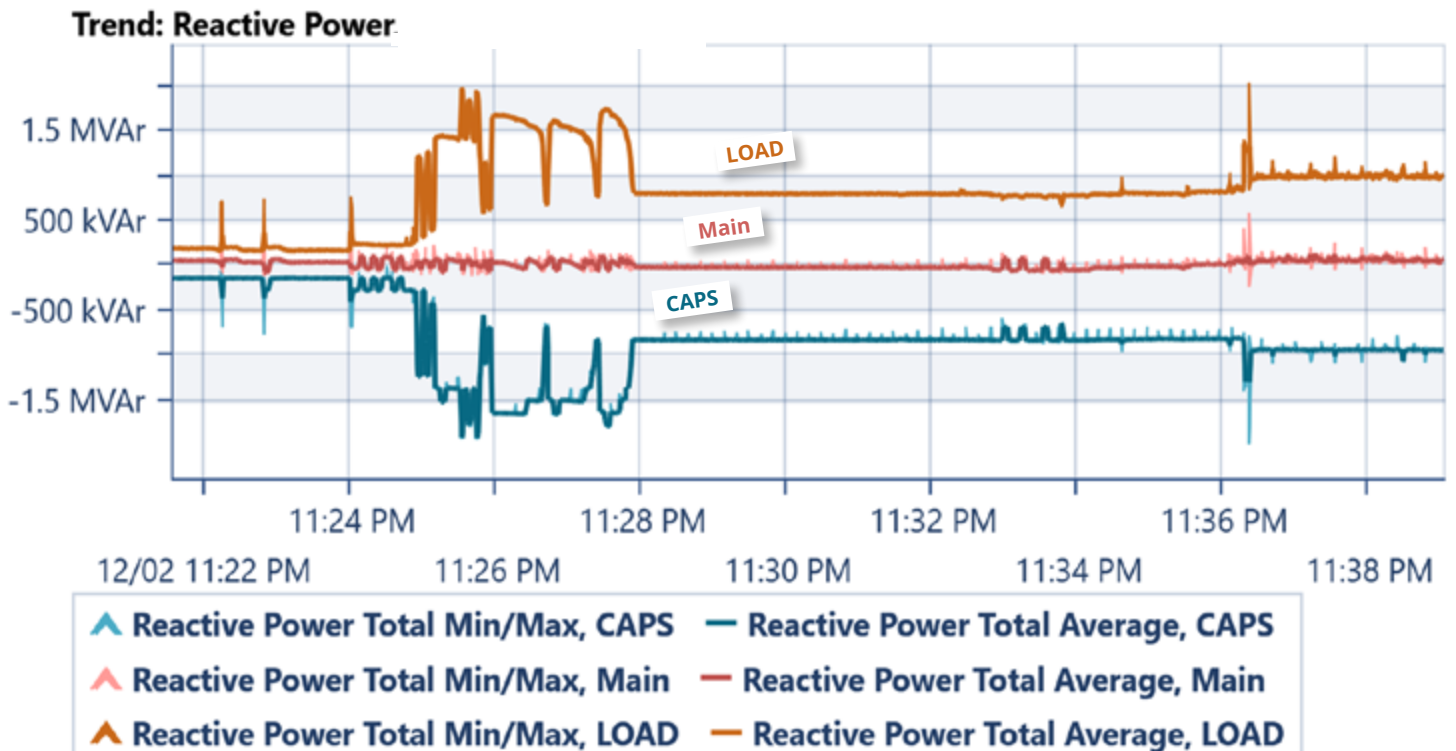

Effective Harmonic Mitigation Built In

A fully integrated Active Harmonic Filter (AHF) based on IGBT technology neutralizes harmonic currents in real time, filtering multiple harmonic orders up to the 50th, keeping THD under 5% for cleaner, more efficient, and more reliable power - all with minimal losses.

Without Elspec's PQ Hybrid

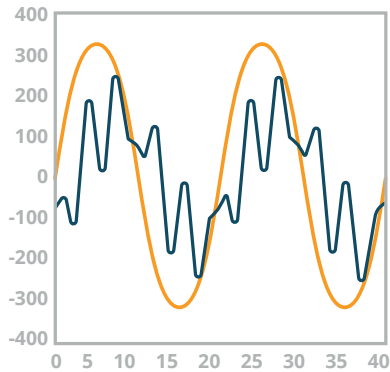

- Voltage (V) - Load current (A)

With Elspec's PQ Hybrid

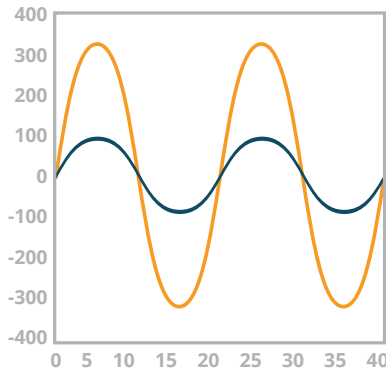

- Voltage (V) - Line current (A)

Stepless Reactive Power Control

In applications such as solar-integrated buildings, grid import can drop to very low levels during peak generation hours, making it difficult to maintain power factor with traditional step-based systems. Elspec's PQ-Hybrid overcomes this by combining step-based compensation with stepless fine-tuning in SVG mode. The integrated Active Harmonic Filter continuously adjusts reactive power between steps, ensuring smooth, precise correction even at low demand levels - eliminating drift, inefficiencies, and utility penalties.

Modular Design

Elspec's PQ-Hybrid solution is modular by design, offering different types of compensation and filtration modules that can be combined based on your specific power quality challenges. Each module is engineered to target distinct load behaviors - from rapid load switching to harmonic-rich or unbalanced systems, ensuring optimized performance, greater efficiency, and a custom fit for every application.

Advanced Monitoring & Full Visibility

Elspec's PQ-Hybrid integrates effortlessly with the Elspec G4 Analyzer and PQSCADA Sapphire platform as an option, giving you full visibility into power quality performance across your facility. From real-time monitoring to in-depth waveform analysis and automated event reporting, you gain actionable insights that help optimize operations, troubleshoot faster, and ensure long-term system health - all from a unified interface.



Technical Information

Specification table for LV system

LV Equalizer System	System power	25kVAr to 3168kVAr
	Network voltage	208V to 690V
	Operational frequency	45-55Hz for 50Hz Network 55-65Hz for 60Hz Network
	Losses	208V – 690V: < 0.8%
	Communication	Isolated RS485 Up to 115k Baud Rate Protocol options: ELCOM (Elspec High-Speed communication protocol) ModBus/RTU (IEEE 754 Floating Point) Full remote control
Switching	Transient free operation	Power electronic switching designed to switch capacitor groups into the network without switching transients. Connection to the network during voltage zero-crossings, providing smooth connection of the groups.
Group Configurations	Number of groups	Up to 12 groups per controller
	Binary switching sequence	1:1:1 1:2:2 1:2:4 1:2:2:4 1:2:4:8
Acquisition Time	Full compensation within one network cycle	Up to 20ms for 50Hz network Up to 16ms for 60Hz network
Control Mode	Main CT installation location	Load only (open loop) Load + Capacitors (close loop)
	Network configuration	Single phase Three phases WYE/DELTA balanced Three phases WYE/DELTA unbalanced
Capacitors	Heavy duty capacitors	450V: 7.5um film thickness 550V: 10um film thickness 690V: 12um film thickness 800V: 14um film thickness
	Maximum ratings	Overcurrent: 4" Inrush current: 200"
Inductors	High power copper inductors	Rated inductance and tolerance: -1.5% / +2.5% Insulation voltage: 8,000V
Operational Modes	Options	Manual Automatic Test Scan option: Can be used in Manual or Automatic modes. This option provides uniform utilization of the capacitor groups, which is carried out by transient free switching between engaged and non-engaged capacitor groups every few seconds in FIFO rotating sequence (First In First Out). Prevents overloading and overheating of the capacitors and inductors.
Display	Structure	Graphic, high contrast FSTN LCD 4.7", Black/White Long life LED backlight Antiglare coated polycarbonate window
	Functions	Menu driven operation Self-explained windows User friendly Easy installation via wizard
	Display Modes	Large Digit Screen – displays 9 numerical values Waveform Screen – displays wave shape together with wave form detailed information Harmonics Screen – displays complete harmonic spectrum, including each harmonic details (amplitude, percentage and phase shift).
Software	Upgrading methods	No Jumpers or switches Firmware can be upgraded by communication All parameters are software selectable, and stored in onboard Flash memory Easy, user-friendly firmware upgrade process Optional features can be enabled just by communication

PC Software	PQScada Sapphire Software	Complete System Remote Control Real Time measurements Time-Of-Use and Cost Allocation Harmonic & Waveform graphic and tabular display Comprehensive Data Logging, including triggers and set points Automatic analysis to international Power Quality standards, such as IEEE 519 (Harmonics standard) Easy Report Generation Exporting to word processor (such as Microsoft Word) and spreadsheets (such as Microsoft Excel) User Friendly on-line help, toolbars and hints Internet and Intranet operation Stand-alone or network versions, allowing intra-net and internet connectivity																		
Switching Module	Electronic switches	Rated voltage: 2400V/Peak Rated Current: 350Amp																		
	Cooling	Temperature controlled, forced air cooling system. Panel mounted Easy for Maintenance External air circulation (air does not pass through the cabinet) Long life, Ball bearings fan																		
	Low losses	400V: 0.35% (3.5W/kVAr) 690V: 0.25% (2.0W/kVAr)																		
Built in Power Quality Measurement System	Simultaneous measurement of the following sections	Mains (total of load and capacitor system) Load Capacitors (system) Combination of Mains, Load and Capacitors. For example, if reactive energy parameter is selected, the user can see the kVAr consumption by the Load , the connected kVAr by the Capacitor System and the result on the Mains .																		
	Calculation method	True RMS measurements (up to 63rd harmonics) Based on FFT algorithm which is carried out cycle by cycle (128 samples per cycle)																		
	Measured parameters	<table border="0"> <tr> <td>Frequency</td> <td>Common</td> </tr> <tr> <td>Phase Current</td> <td>N, L1, L2, L3</td> </tr> <tr> <td>Phase to phase Current*</td> <td>L1-2, L2-3, L3-1</td> </tr> <tr> <td>Phase Voltage</td> <td>N, L1, L2, L3</td> </tr> <tr> <td>Phase to Phase Voltage</td> <td>L1-2, L2-3, L3-1</td> </tr> <tr> <td>Active Power (kW)</td> <td>L1, L2, L3, Total</td> </tr> <tr> <td>Reactive Power (kVAr)</td> <td>L1, L2, L3, Total</td> </tr> <tr> <td>Apparent Power (kVA)</td> <td>L1, L2, L3, Total</td> </tr> <tr> <td>Power Factor</td> <td>L1, L2, L3, Total</td> </tr> </table> <p>*Note: Unique feature: internal current of feeder transformer (delta secondary)</p>	Frequency	Common	Phase Current	N, L1, L2, L3	Phase to phase Current*	L1-2, L2-3, L3-1	Phase Voltage	N, L1, L2, L3	Phase to Phase Voltage	L1-2, L2-3, L3-1	Active Power (kW)	L1, L2, L3, Total	Reactive Power (kVAr)	L1, L2, L3, Total	Apparent Power (kVA)	L1, L2, L3, Total	Power Factor	L1, L2, L3, Total
	Frequency	Common																		
	Phase Current	N, L1, L2, L3																		
	Phase to phase Current*	L1-2, L2-3, L3-1																		
Phase Voltage	N, L1, L2, L3																			
Phase to Phase Voltage	L1-2, L2-3, L3-1																			
Active Power (kW)	L1, L2, L3, Total																			
Reactive Power (kVAr)	L1, L2, L3, Total																			
Apparent Power (kVA)	L1, L2, L3, Total																			
Power Factor	L1, L2, L3, Total																			
Thd, harmonic spectrum, and waveform analysis for	<table border="0"> <tr> <td>3 line current of Mains</td> <td>DELTA, WYE</td> </tr> <tr> <td>3 line-line current of Mains</td> <td>DELTA</td> </tr> <tr> <td>3 line current of Load</td> <td>DELTA, WYE</td> </tr> <tr> <td>3 line-line current of Load</td> <td>DELTA</td> </tr> <tr> <td>3 line current of Capacitors</td> <td>DELTA, WYE</td> </tr> <tr> <td>3 Phase to Neutral voltage</td> <td>DELTA, WYE</td> </tr> <tr> <td>3 line Phase to Phase voltages</td> <td>WYE</td> </tr> <tr> <td>Neutral current</td> <td>WYE</td> </tr> <tr> <td>Neutral voltage</td> <td>WYE</td> </tr> </table>	3 line current of Mains	DELTA, WYE	3 line-line current of Mains	DELTA	3 line current of Load	DELTA, WYE	3 line-line current of Load	DELTA	3 line current of Capacitors	DELTA, WYE	3 Phase to Neutral voltage	DELTA, WYE	3 line Phase to Phase voltages	WYE	Neutral current	WYE	Neutral voltage	WYE	
3 line current of Mains	DELTA, WYE																			
3 line-line current of Mains	DELTA																			
3 line current of Load	DELTA, WYE																			
3 line-line current of Load	DELTA																			
3 line current of Capacitors	DELTA, WYE																			
3 Phase to Neutral voltage	DELTA, WYE																			
3 line Phase to Phase voltages	WYE																			
Neutral current	WYE																			
Neutral voltage	WYE																			
Energy	Active Energy (kWh) Reactive Energy (kVARh) Stores energy data every 15 minutes for previous																			
Controller Specifications	Power supply	230V, 50/60Hz																		
	LCD display	Size: 94x76mm Resolution: Graphic 160x128 pixels Type: FSTN, LED backlight																		
	Frequency	30 to 70 Hz																		
	Power consumption	10VA																		
	Operating temperature	-20 to +55°C																		
	Communications	RS-485 communication port																		
	Protocol	ELCOM (Elspec's protocol), Modbus/RTU																		
	Alarm	Voltage free N.O. / N.C., relay, max 250 VAC / 2A																		
	Protection class	IP 40																		
	Dimensions	144x144x138mm																		
	Weight	1.4 kg																		
	Storage temperature	-25 to +70°C																		
	Sensors	Three 5A current sensors for Mains/Load currents Two 5A current sensors for capacitors system current Four voltage sensors (up to 500V phase to ground)																		
	User keys	Five soft touch buttons																		
Controller box standard	Electromagnetic compatibility: EN50081-2, EN50082-2, EN55011, EN61000-4-2/3/4/5, EN50204, EN50141 Safety standards: EN61010-1, EN50439-1																			

Specification table for active harmonic filter

Rated voltage (range)	400V (228-456V)	480V (384-552V)	690V (483-793V)
Individual module capacity	60A, 100A, 150A	50A, 60A, 100A, 150A	50A, 100A
Mains frequency	50/60Hz (range: 45-62Hz)		
Neutral filtering capability	3 times the rated filter current (in case of 4 wire device)		
Harmonic current compensation range	2 nd to 50 th harmonic order or specified harmonics 0-110%		
Rate of harmonic reduction	> 97% ₁		
Typical power losses	< 3% (depending of the load)		
Target power factor	Adjustable from -1 to 1		
Switching/control frequency	20kHz/20kHz		
Reaction time	Approx. 50μs		
Overall response time	< 5ms		
Harmonic compensation	Available		
Reactive power compensation	Available		
Unbalance compensation	Available		
Communication ports	RS485 and network port (RJ45)		
Communication protocols	Modbus RTU, TCP/IP (Ethernet)		
Fault alarm	Available, max. 500 alarm records		
Noise level	< 56dB upto 100A, < 65dB for 150A		
Protection functions	Overvoltage, undervoltage, short-circuit, inverter bridge inverse, overcompensation		
Operating temperature	-10 to +50°C (higher temperatures with derating)		
Relative humidity	5-95%, non-condensation		
Cooling	75,115,222, 336,360L/sec (25-35,50-60,75-100, 150A)		
Protection class	IP 20 according to IEC 529 (customizable)		
Panel color	RAL7035 light grey		
Altitude	1500. 1500-4000m the power decreases by 1% for every additional 100m, according to GB/T3859.2		
Qualifications	CE, IEEE 61000		
Compliance with standards	IEEE 519, ER G5/4		

Mechanical Drawings

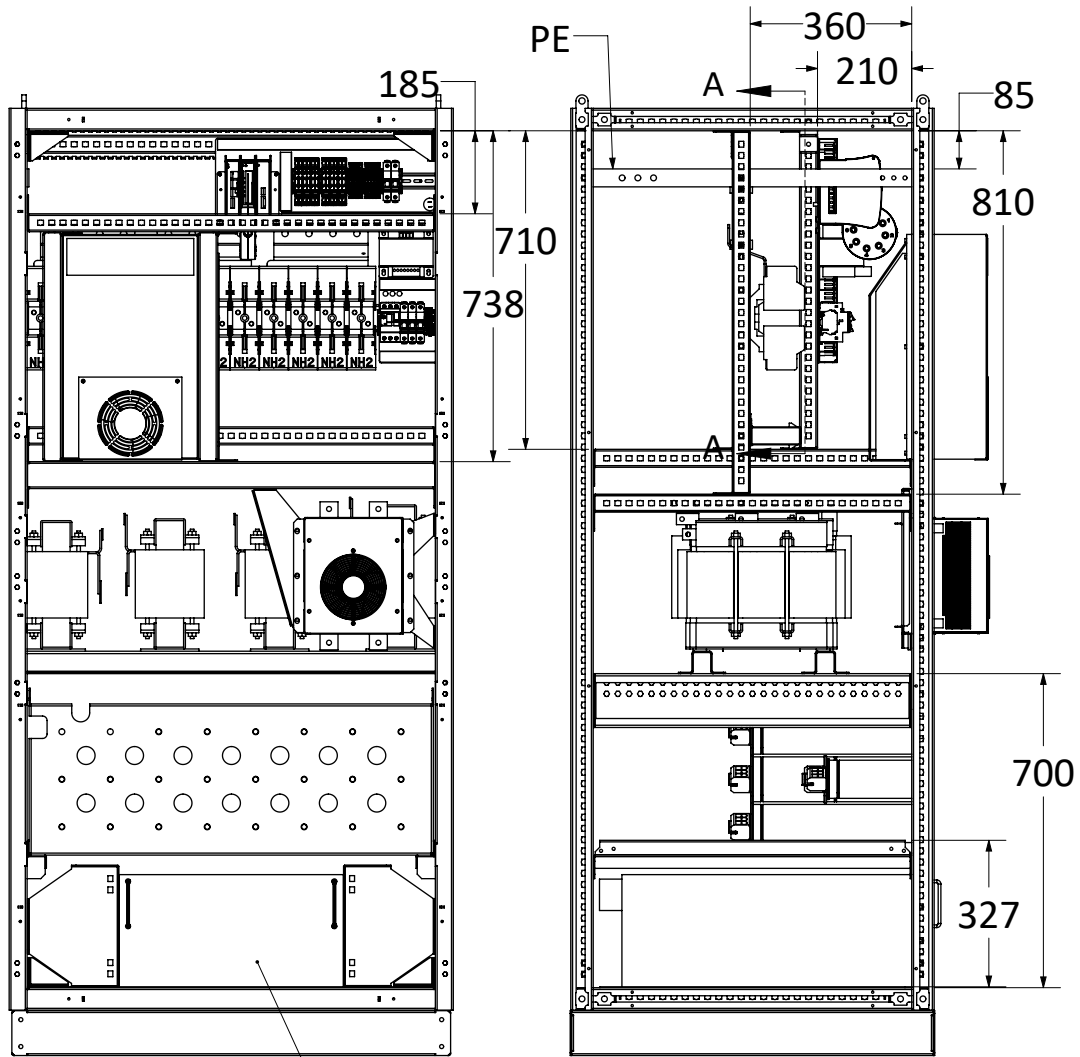

AHF rack module

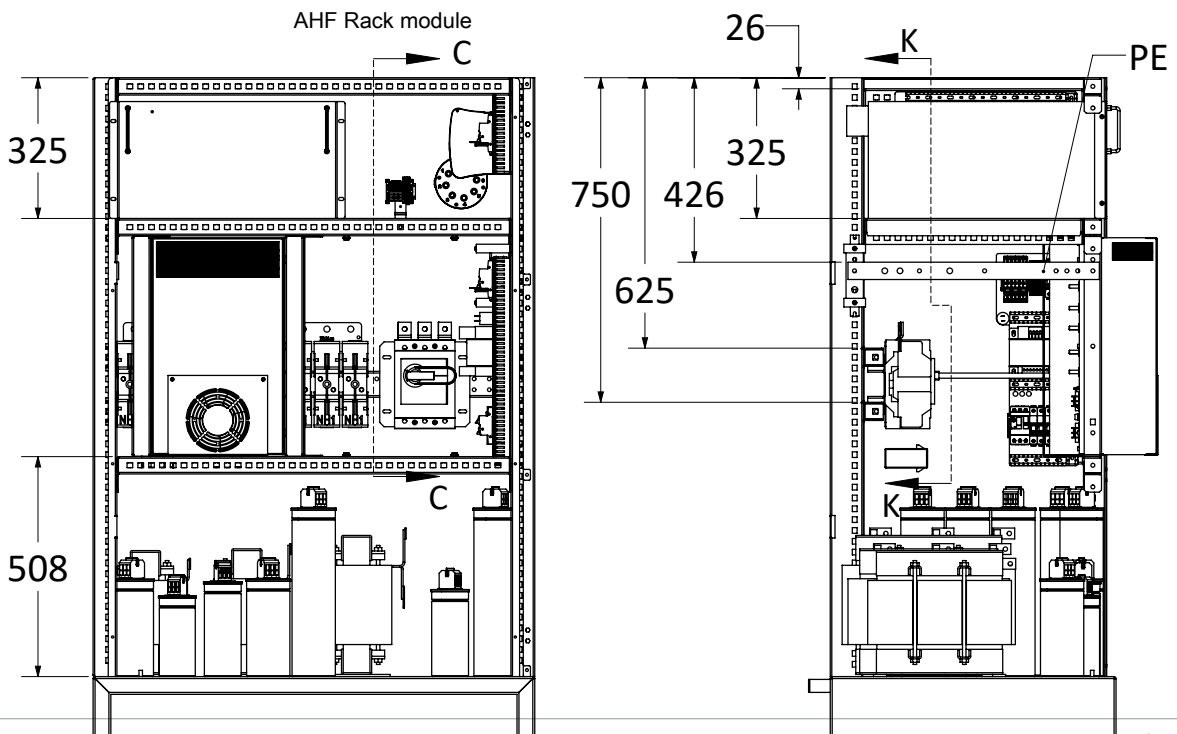

A photograph of a server rack with a large, dark, rectangular device installed. The device has the 'Elspec' logo at the top. The rack is filled with various components, including a control panel on the right side.

Safety and Protection You Can Trust

Elspec's PQ Hybrid solution is engineered for maximum safety and reliability, offering a full suite of protective features to ensure uninterrupted operation and safeguard all connected equipment:

**Overload
Protection**

**Short-Circuit
Protection**

**Resonance
Protection**

**Overtemperature
Protection with
Fan Fault Alarms**

**Overvoltage and
Undervoltage
Protection**

These built-in protections, combined with Elspec's robust design and real-time monitoring capabilities, make the Hybrid system ideal for mission-critical environments where downtime is not an option.

Worldwide Innovator in Power Quality

Since 1988 Elspec has developed, manufactured and marketed proven power quality solutions far exceeding our clients' needs and expectations. Our innovations not only simplify the understanding of the quality of power itself, but are also highly compatible, making it suitable for any business and/or application. Elspec's international team of professionals with extensive experience in electrical engineering, are ready to provide a tailor-made strategy that will enable a sustainable and efficient use of your electrical energy.



International

Elspec Ltd.
info@elspec-ltd.com

North America

Elspec North America, Inc.
info@elspecna.com

Europe

Elspec Portugal Lda.
info@elspeceurope.com

India

Elspec Engineering India Pvt Ltd.
info@elspec.in

Región Andina

Elspec Andina
info@elspec.com.co

For all Products & Applications Visit us at:
www.elspec-ltd.com



Elspec is a registered trademark. All trademarks are the property of their respective owners
July 2025